

USER'S GUIDE

LEONICS®

EXPLORER

explore new concept UPS
explore convenience
explore advantages

Authorized Distributor

● www.leonics.com ● e-mail : global_business@leonics.com ● LEN.MAN.UPS.114 Rev.1.00/2006



INTRODUCTION

The EXPLORER UPS is a compact uninterruptible power supply for office automation equipment (computers and peripherals such as monitors, modem, printers, fax machines, etc.). Its major function is to eliminate any power problems such as a blackout, brown out, surge, spike, noise, etc. that might cause malfunction of the load causing work interruption. With its Advanced Micro-processor Control, when the UPS detects any abnormal conditions, it will respond instantaneously. It also has special features: AVR (Automatic Voltage Regulator or stabilizer), Surge Suppression and Backup power supply system.

PHYSICAL DESCRIPTION

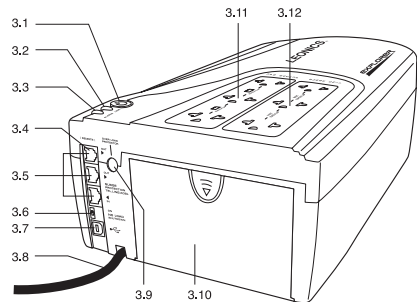

- 3.1 POWER button:** The button to turn on and turn off the UPS
- 3.2 LINE indicator:** Indicates that the UPS is operating under normal condition.
- 3.3 ALARM indicator:** Indicates the UPS operating status when power fails or there is fault. The following tables show the meaning of the indicators and alarm.

LINE	ALARM	Light condition	Audible alarm	UPS status
When user starts the UPS or the UPS starts automatically after the utility power returns to normal.				
Green	Red	Blink 2-3 times	1 beep sound is ON at the last blink.	Battery is in a good condition.
-	Red	Lit For 2 seconds	Long beep for 2 seconds.	Battery power is very low.
When the UPS is ON.				
Green	-	Lit	-	The UPS is operating normally.
Green	-	Blink	-	The UPS received the shutdown command from the computer and it will shut down in 2 seconds.(option)
-	Red	Lit 1 second OFF 3 seconds	Beep every 3 seconds for 1 minute.	Black out or Power fails.The UPS is supplying backup power from battery.
-	Red	ON 0.5 second OFF 0.5 seconds	Beep every 0.5 seconds	Battery backup power is running out.
-	Red	ON	Long beep	UPS output shorts circuit.UPS will automatically shut down.

- 3.4 Remote port:** The port to connect to a remote control (option)
- 3.5 Surge Protection for Telephone Line / Modem / ADSL (available in specific model only):** The ports to plug in telephone jacks before fax machine, modem, telephone, computer or ADSL equipment in order to protect them from surge.
- 3.6 No load shutdown setting switch (available in specific model only):** The switch to enable automatic shutdown when there is no load and power fails. (No load means the total power of all loads are lower than 60 W.) The factory default setting is OFF or disabled.
- 3.7 USB port (available in specific model only):** The communication port for connecting the UPS to PC to transmit the signal via Easy-Mon X software.
- 3.8 AC input power cord:** The input power cord to connect to utility line; user can place the input power cord to Explorer either top direction or left direction in the power cord tray.
- 3.9 Overload breaker:** Over current or short circuit protection component
- 3.10 Battery cover:** Slide this cover to replace the battery.
- 3.11 UPS BACKUP outlet:** The output outlets for connecting the equipments such as computers, monitors, modem, printer and fax machine to the UPS backup power system
- 3.12 SURGE ONLY outlet:** The extra outlets which are connected to the surge protection system for the equipments that do not require backup power such as laser printer. These output outlet do not have (backup) power when utility line fails.

INSTALLATION AND OPERATION

- 4.1 Connect a signal cable to PC at USB port of the UPS and communicate with the PC via Easy-Mon X software. The standard product does not have this feature; it exists in specific model only.

Note: User can install Easy-Mon X software from the CD-ROM or download the software at www.leonics.com.

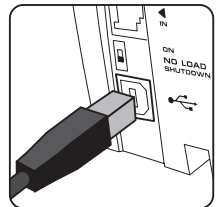

- 4.2 Connect a remote control jack at "Remote" port. If there is no remote control to be connected, user can connect a cable from telephone, fax machine, modem or ADSL equipment to protect them from surge.

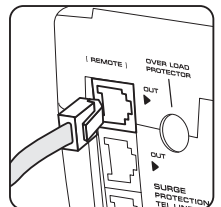

4.3 Connect a telephone cable at Surge Protection for Tel./ Modem / ADSL port.

IN : Connect telephone line to the UPS.

OUT : Connect telephone line from the UPS to the input socket of telephone, fax machine, modem or ADSL equipment.

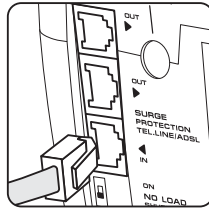

Note: To gain proper benefit from telephone line surge protection, your electricity system should have an electric ground. If there is no electric ground wire, there can be data transferring problems and loss of protection of the connecting devices.

4.4 Set the NOLOAD SHUTDOWN switch to 'ON' as shown (available in specific model only), if you want the UPS Shutdown automatically in backup mode when the total power consumption at loads is less than 60 Watt in order to save energy and prolong battery life. (The factory default setting is OFF.)

If your load is a PABX which consumes power less than 60 W, set the NO LOAD SHUTDOWN switch to 'OFF'.

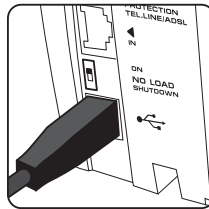

4.5 Plug the loads such as computers, printers, modem and etc to UPS BACKUP outlets.

Caution : Total Power consumption of loads should not exceed UPS rated power.

4.6 Plug the non-required backup power loads such as laser printer to SURGE ONLY outlet which are connected surge protection circuit. These outlet do not supply backup power when utility line fails.

4.7 Plug AC input power cord of the UPS to utility line.

4.8 Turn on power button of the UPS and then turn on the loads.

Note: Once Power button is turned on, user can turn on and turn off the UPS by remote control. (Option)

4.9 When the battery is already charged, user can test the UPS as follow

- Turn on the UPS and wait until the LINE indicator is lit
- Turn on the loads.
- Unplug the UPS power cord from utility line to simulate blackout.
- UPS supplies backup power to the loads, LINE indicator is OFF, alarm sounds and ALARM indicator blinks slowly simultaneously.
- Plug the UPS power cord to utility line.
- No alarm sound, ALARM indicator is OFF and LINE indicator is lit.

4.10 After finishing your work with the computer, shut it down and turn off the UPS to keep sufficient battery power is available when there is a blackout.

4.11 If you have to store UPS for a long period of time, the UPS need to be recharged every three months to preserve the condition of the internal battery as follow

- Plug the UPS power cord to utility line.
- Turn on the POWER button
- Leave the UPS connected to utility line for at least 8 hours.

TROUBLESHOOTING

If the EXPLORER UPS does not operate properly and you cannot solve the problem using the troubleshooting information in this user's guide, please contact your LEONICS local distributors, LEONICS Service Center, Send e-mail to support@leonics.com.

Symptoms	Possible causes	Solutions
Turned on power buttons. LINE indicator is off and UPS alarm sounds. But the UPS operates normally	UPS power cord is not properly plugged into utility outlet socket.	Properly plug the UPS power cord.
	There is no power supply to AC input power cord.	Move the UPS to another wall outlet. If the symptom persists, please contact us.
	Overload breaker tripped.	Press the overload breaker to reset. If the symptom persists, please contact us.
ALARM indicator blinks and alarm sounds simultaneously. Overload breaker does not trip.	UPS power cord is not properly plugged to utility outlet socket.	Properly plug the UPS power cord.
	Main AC breaker is tripped.	Reduce the loads that connect to the same wall outlet source as the UPS or move the UPS to another wall outlet.
ALARM indicator is lit and alarm sound long beep. The UPS does not operate. Overload breaker tripped.	UPS is overloaded or short circuited.	1. Turn off the UPS and reduce some loads until the total power consumption of all loads is less than UPS power rating. 2. Press the overload breaker to reset.
During blackout, ALARM indicator and alarm sound are still ON. Overload breaker does not trip but the UPS does not supply backup power.	The UPS is overloaded.	Turn off the UPS and reduce some loads until the total power consumption of all loads is less than UPS power rating.

Symptoms	Possible causes	Solutions
When black out, LINE indicator, ALARM indicator and alarm sound are OFF. The UPS does not supply backup power.	The UPS runs out of backup power.	Once the utility line turns back to normal, turn on the UPS for at least 8 hours to recharge its battery.
UPS supplies backup power shorter than specific time or very short time.	The UPS is overloaded.	Reduce some loads until the total power consumption of all loads is less than UPS power rating.
	Battery is deteriorating.	Turn on the UPS for at least 8 hours to recharge its battery, then test backup power. If the symptom persists, please contact us.
Easy-Mon X software cannot communicate with the UPS or the software shows "Communication Error".	<ul style="list-style-type: none"> - The USB cable is disconnected and reconnected while the software is running. - The USB cable is not properly plugged. 	Exit Easy-Mon X software and reconnect the USB cable properly. Then, restart the computer and load the software.

BATTERY REPLACEMENT

Caution: Although battery replacement can be made when the UPS is operating, we recommend you to turn off the loads and UPS before replace the battery for your own safety.

- 6.1 Press and slide down the battery cover to open to battery compartment. Then, lift another end of the UPS to let the battery come out.

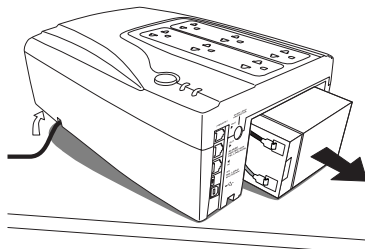
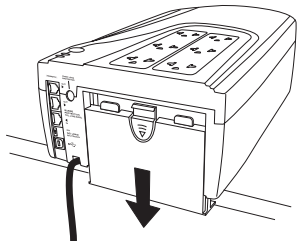

- 6.2 Disconnect the black and red wires from the battery terminals. Then pull the battery out and replace with a new one.

Note: Battery can be recycled and needs proper elimination. It consists of lead which harms to our environment and healths. Please return the battery to us or our service center.

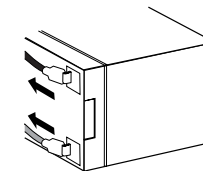

- 6.3 Reconnect the black (-) wire to the black terminal and red (+) wire to the red terminal.

Caution: - Keep the red and black wire terminals apart, they might short circuit.
- The replacement battery must be same type and same rating as original.

- 6.4 Replace the battery cover and continue using the UPS normally.

SOFTWARE INSTALLATION

The Easy-Mon X software is contained in the CD-ROM which bundles with the product (available in specific model only). It is also available to download at www.leonics.com.

Note: Connect the USB cable first. Then, turn on the UPS and computer to install the Easy-Mon X software.

- 7.1 Install the Easy-Mon X software from CD-ROM: Insert the Easy-Mon X Software CD into CD-ROM drive. LEONICS presentation will show on the computer monitor. Press ESC button on the keyboard to exit the Presentation. The Easy-Mon CD window will show on screen. Click "Easy-Mon X Install" button, then select "How to install USB driver" to view USB driver installation procedure and then follow the instruction guided on screen to install USB driver. Restart the computer.
- 7.2 Download the Easy-Mon X software from internet: Click Download menu and select Software submenu. You will reach software download page. Select the UPS model and follow the instruction guided on screen to download the USB driver and Easy-Mon X software.
- 7.3 When Easy-Mon X is completely installed, go to Start > Programs > Easy-Mon X > Easy-Mon X Setup and select Communication port. Under LEONICS UPS Series, select Generic Series (Dry Contact) and Easy-Mon Adapter. Then, click OK.
- 7.4 Set UPS shutdown time to shutdown when the battery level is low or utility line fails, then click ok. Record the setting and exit Easy-Mon X Setup.
- 7.5 Open the Easy-Mon X Spy program to monitor power data.