

USER'S GUIDE

LEONICS®

**NB S-series
NBP S-series**

True on-line Double Conversion
Sine Wave UPS

CONTENTS

| | |
|--|-----------|
| 1. SAFETY INSTRUCTIONS | 1 |
| 2. INTRODUCTION | 2 |
| 3. DISPLAY PANEL AND COMPONENTS | 5 |
| 3.1 Display panel | 5 |
| 3.2 Components | 7 |
| 4. INSTALLATION | 12 |
| 5. OPERATION | 17 |
| 5.1 Start-up the UPS | 17 |
| 5.2 Turning on and turning off the UPS for the next time | 17 |
| 5.3 When blackout or power fails | 17 |
| 5.4 When UPS is overloaded | 18 |
| 5.5 No load shutdown mode | 18 |
| 5.6 Economy mode | 18 |
| 5.7 Sleep mode | 18 |
| 5.8 UPS self-test | 18 |
| 5.9 Self-test cancellation | 18 |
| 5.10 Mute alarm sound | 19 |
| 5.11 Force bypass | 19 |
| 5.12 Manual maintenance bypass | 19 |
| 5.13 Emergency Power Off (EPO) | 19 |
| 6. LCD DISPLAY DESCRIPTION | 20 |
| 7. SETTING | 23 |
| 7.1 Enter password | 23 |
| 7.2 System control setting | 24 |
| 7.3 Time and date setting | 24 |
| 7.4 Parameter setting | 26 |
| 8. MAINTENANCE | 27 |
| 9. TROUBLESHOOTING | 28 |
| 10. SOFTWARE INSTALLATION | 30 |

SAFETY INSTRUCTIONS

Please read carefully and follow this LEONICS NB S-series/NBP S-series UPS guide.

Important : Please keep this manual for reference in order to use the LEONICS UPS properly and safely. This user's guide contains instructions for installation, maintenance, operation and unit etc.

For product safety, please check this product annually by our service qualified personnel or if there are any symptoms of problems which are not mentioned in this guide or any queries, please contact your LEONICS local distributors, LEONICS Service Center, send e-mail to support@leonics.com or visit www.leonics.com.

For your convenience and quick reference for LEONICS UPS service, please fill the requested information in the blanks below.

LEONICS UPS model: _____
Serial number: _____
Purchased date: _____
Purchased from: _____

CAUTION

Risk of electric shock, DO NOT remove cover. No user serviceable part inside, please refer servicing to qualified service personnel.

1.1 Electrical Safety

- 1.1.1 Do not work alone where there is danger of shock.
- 1.1.2 Contact with live conductors will cause burns and dangerous electric shock.
- 1.1.3 Please allow ONLY a certified electrician to wire your system permanently.
- 1.1.4 Periodically check your cable, outlets and power source to make sure that they are in good condition.
- 1.1.5 To reduce risk from electric shock if you can not find the electrical ground () of the building, unplug the UPS from the AC source before plug in your load at the rear side of the UPS. Then, plug in the UPS to AC source.
- 1.1.6 Do not touch any metal parts or any electrical connection when UPS is operating.
- 1.1.7 It is recommended to connect the UPS to a three wire AC source (two live wires and ground) which connects to a protected circuit such as employs a fuse or circuit breaker.

1.2 CAUTION ! Safety guide for installation and operation

- 1.2.1 Before installation or using this unit, read all instructions, caution markings on the UPS and all connected load, and all sections of this user guide.
- 1.2.2 Install this unit in a temperature and humidity controlled indoor area with adequate air flow and away from chemical particles or flammable substances. Avoid installing the unit near radio transmission station, heat dissipation equipment and direct sunlight.
- 1.2.3 This unit has ventilation grills. Ensure that sufficient ventilation is provided. DO NOT block the ventilation grills.
- 1.2.4 Use insulated tools to reduce your risk of electric shock.
- 1.2.5 Remove all jewelry or other metal objects such as rings, necklace, bracelets and watches when installing this product.
- 1.2.6 Properly wiring the cables as shown in the wiring diagram.

- 1.2.7 Before connecting the communication interface signal cable to computer, turn off the UPS and disconnect it from the utility line.
- 1.2.8 Turn on the UPS before turn on the load to prevent surge from the loads.
- 1.2.9 DO NOT connect utility power to the UPS OUTPUT. This may cause the UPS damaged.
- 1.2.10 When heavy rain, avoid using electronic instruments including UPS to prevent it from lightning.
- 1.2.11 Use soft cloth to clean the UPS when it is OFF. DO NOT clean it with solvent.
- 1.2.12 DO NOT use the UPS with life recovery instruments. The failure of UPS may cause life recovery instruments failure or effect to their performance or effect to the safety system of those instruments.

1.3 Warning ! Battery Safety

- 1.3.1 The UPS has hazardous voltages inside, do not disassemble any parts of UPS except for the battery.
- 1.3.2 Users are not allowed to repair, recondition or disassemble the UPS. This must be done by LEONICS qualified technicians only. The battery that is inside your UPS can be recycled. It contains LEAD, which is harmful to health and the environment. If it can not be disposed of properly.
- 1.3.3 Do not dispose of batteries in a fire. They may be exploded.
- 1.3.4 Do not disassemble batteries. They contain poisonous electrolyte which is harmful to your skin and eyes.
- 1.3.5 Replace batteries with the same type and rating and follow the proper battery replacement procedure.
- 1.3.6 When replacing a battery, use tools with insulated handles and remove any watch, rings or other metal objects that you wear in order to avoid electric shock.
- 1.3.7 If user has to keep the UPS or does not use it for long time, recharge the battery every 3 months in order to preserve the battery. To recharge the battery, connect it to the AC utility and turn on the UPS for 8 hours.

Vocabulary

| | |
|-------|--|
| Load: | Any equipment which is plugged into the UPS and gets power from the UPS such as a computer, printer, fax machine or modem. |
| UPS : | NB S-Series / NBP S-series UPS |
| VA : | The unit of UPS power rating showing its capacity. |

INTRODUCTION

2.1 General

LEONICS NB S-series/NBP S-series UPS is a True On-line Double conversion uninterruptible power supply which is the highest quality power protection system to protect against all utility power problems. With LED and LCD displays, user can view the UPS operating status anytime.

True On-Line Double conversion system has two operation steps. First, it convert alternative current (AC) to direct current (DC) Some of the direct current will flow to charge the battery to be backup power and the rest will invert to alternative current and then supply to load. If the AC input is disconnected, the UPS will invert the direct current from battery to alternative current and supply to load. UPS will supply AC power to load continuously.

2.2 Features

- True On-line pure sine wave
- Microprocessor controller
- Stable output frequency (Crystal control)
- Over current and short circuit protection
- Built-in output isolation transformer
- Load safe battery test (available in NBP S-series only)
- EMI/RFI and power line noise protection
- Automatic bypass overload protection
- Automatic bypass transfer switch (zero transfer time)
- DC start (AC start without battery (option))
- Manual self-test
- RS-232 communication port
- Sealed lead acid maintenance free battery
- LED indicator and LCD display

2.3 UPS Operation

2.3.1 When utility power and loads are normal

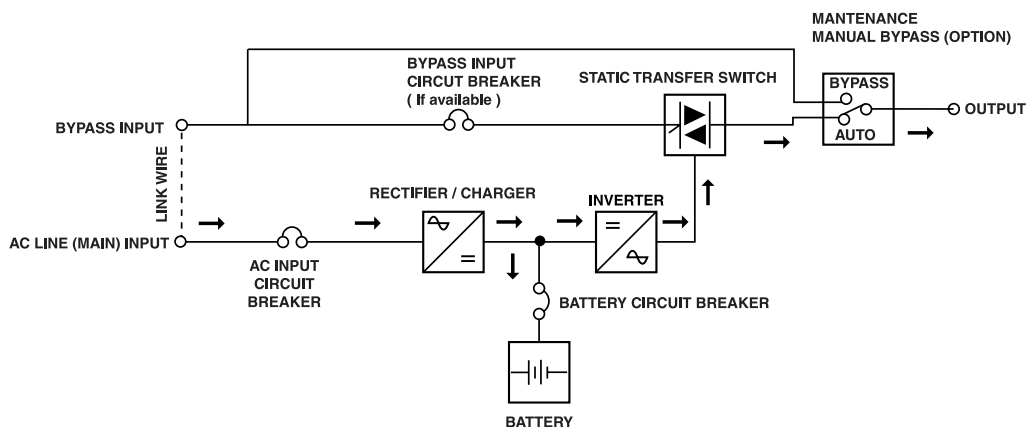

Above diagram shows how UPS works when utility power (AC line) is normal and UPS has less than 100% load. UPS converts utility power from alternative current (AC) to direct current (DC) at RECTIFIER. Some of the DC power flow to charge battery to be backup power and the rest flow directly to INVERTER to invert power to high quality and stable AC power. Then, supply to load.

2.3.2 When utility power is normal but overload.

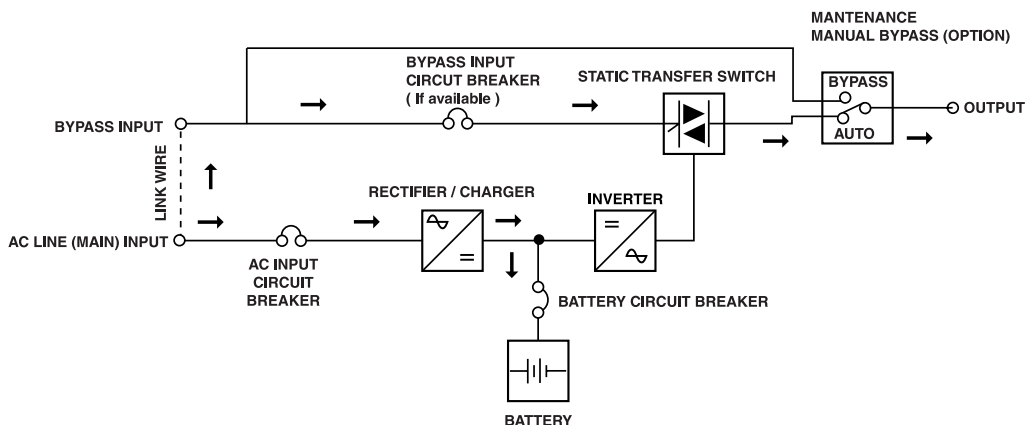

Above diagram shows how UPS works when utility power is normal and UPS has more than 100% load. UPS converts utility power at RECTIFIER / CHARGER section to charge battery only. The power supplied to load directly is from utility line.

2.3.3 When utility power fail but loads are normal

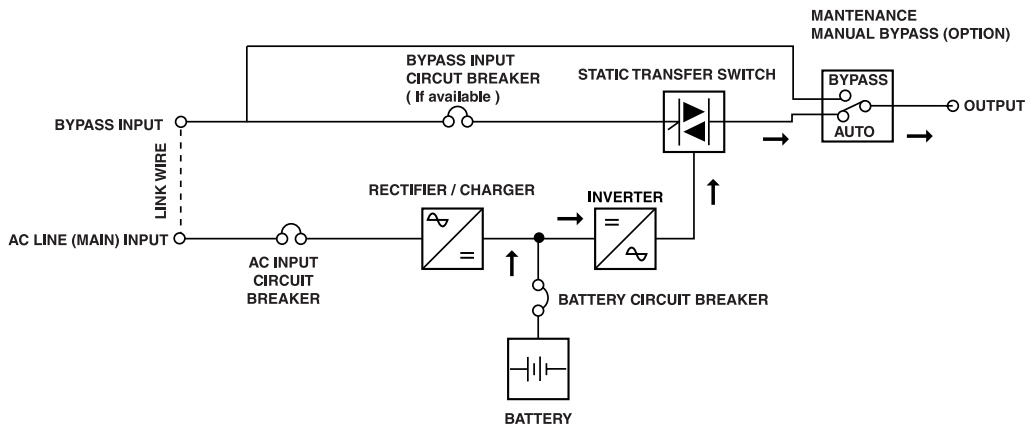

Above diagram shows how UPS works when utility power fails such as blackout, brownout, under voltage, over voltage or frequency fault and UPS has less than 100% load. UPS draws backup power from battery to invert to AC power and continuously supplies to load.

2.3.4 Use maintenance bypass switch when UPS is malfunction (option)

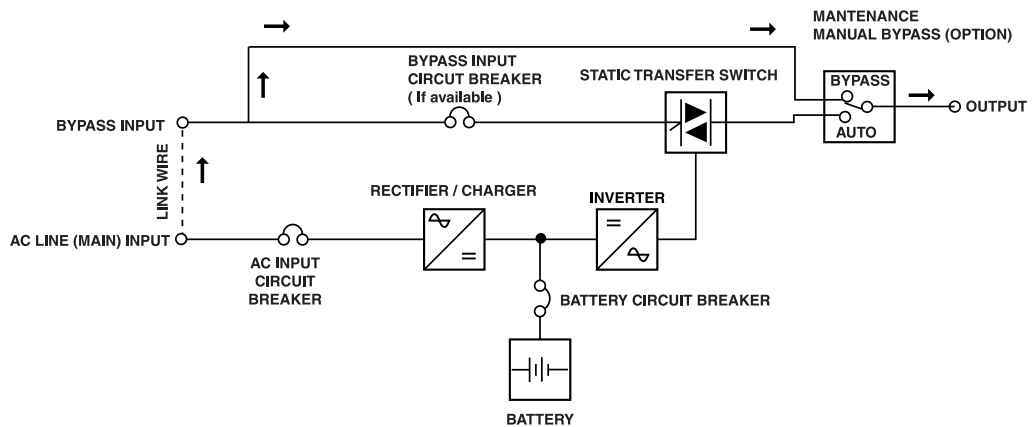

Above diagram shows how system works when UPS is malfunction. User is allow to temporary run the system by turning the manual bypass switch from position A to B or at BYPASS position. All loads will get power supplied directly from utility line. Then, contact us or our nearest service center.

DISPLAY PANEL AND COMPONENTS

3.1 Display panel

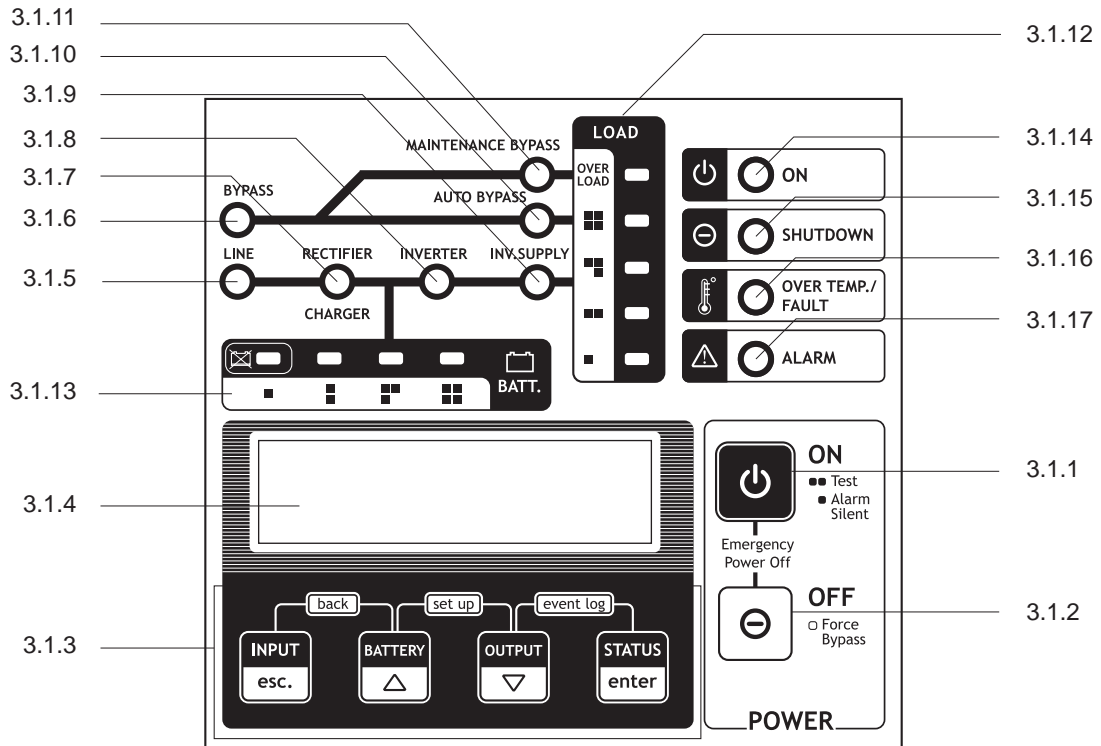

3.1.1 **ON button:** The button to turn on the UPS, test the operation and mute alarm sound.

3.1.2 **OFF button:** The button to turn off the UPS and force the UPS to bypass the power source.

3.1.3 **INPUT, BATTERY, OUTPUT and STATUS buttons:** The buttons to show the UPS parameters on LCD display.

3.1.4 **LCD display:** The screen to display parameter values.

3.1.5 **LINE indicator:** Indicate status of main power source.

Lit means the input voltage is normal.

Off means the input voltage of the main power source is out of range.

3.1.6 **BYPASS indicator:** Indicates status of bypass power source.

Lit means the voltage and frequency of the bypass power source is in the range.

Off means the voltage of the bypass power source is out of range or the frequency is out of synchronized range.

3.1.7 **RECTIFIER/CHARGER indicator:** Indicates status of RECTIFIER and CHARGER section.

Lit means RECTIFIER and CHARGER operate normally.

Blink means RECTIFIER and CHARGER are just starting the operation.

Off means RECTIFIER and CHARGER stop operating.

3.1.8 **INVERTER indicator:** Indicates status of INVERTER section.

Lit means INVERTER section is operating and synchronizing frequency with the bypass power source.

Blink means INVERTER section is operating but does not synchronize frequency with the bypass power source.

Off means INVERTER section stop operating.

3.1.9 INV.SUPPLY indicator: Indicates status of power from INVERTER section which supplies to loads.

- Lit means loads consume protected power from the UPS.
- Off means the protected power from the UPS does not supply to loads.

3.1.10 AUTO BYPASS indicator: Indicates status of BYPASS power source which is supplying to loads directly when overload, inverter fault or force bypass condition.

- Lit means loads consume power from BYPASS power source directly by press and hold OFF button to force bypass condition.

Slow blink means loads consume power from BYPASS power source directly automatically.

- Off means there is no power from BYPASS power source supplying to load.

3.1.11 MAINTENANCE BYPASS indicator: Indicates status of BYPASS power source which is supplying to loads directly when MAINTENANCE BYPASS SWITCH is set at position BYPASS (B)

- Lit means loads consume power through MAINTENANCE BYPASS SWITCH.

Blink means MAINTENANCE BYPASS SWITCH is set at position AUTO (A) .

3.1.12 LOAD LEVEL indicator: Indicates the load quantity comparing to full capacity of the UPS. The indicator shows from 25% (bottom LED) to OVERLOAD (top LED).

1st (bottom) lamp is lit means total load quantity is higher than no load condition level.

2 lamps are lit means total load quantity is between 26-49%.

3 lamps are lit means total load quantity is between 50-74%.

4 lamps are lit means total load quantity is between 75-99%.

5 lamps are lit means total load quantity is over 100%. The UPS is overloaded.

Recommend to reduce some loads.

3.1.13 BATTEY LEVEL indicator: Indicates the level of battery power comparing to the full level. The indicator shows from replace battery (bar left LED) to full battery (bar right LED).

1st (left) lamp is lit means the battery power is very low and blinks when the battery should be replaced.

2 lamps are lit means the battery power is low and blinks to alarm.

3 lamps are lit means the battery power is moderate.

4 lamps are lit means the battery power is full.

3.1.14 ON indicator: Indicates the UPS operation normally.

Lit means the UPS is operating normally.

Very slow blink means loads consume power from BYPASS power source directly by press and hold OFF button to force bypass condition.

Slow blink means the UPS stop operating and waits to restart by startup schedule.

Fast blink means the UPS is testing the operation.

Off means the UPS stop operating.

3.1.15 SHUTDOWN indicator: Indicates the UPS stop operation or standby operation.

Lit means the UPS stop operating or UPS is in standby mode.

Slow blink means the UPS is going to shutdown due to a command from the computer.

Fast blink means the UPS is going to shutdown due to low battery or overload.

Off means the UPS does not standby or is not going to shutdown.

3.1.16 OVER TEMP./FAULT indicator: Indicates the UPS is over temperature or UPS is malfunction.

Lit means the UPS operates abnormally.

Fast blink means the UPS is over temperature.

Off means the UPS operates normally or is normal temperature.

3.1.17 ALARM indicator: Indicates the UPS has fault.

Blink means the UPS alarms fault.

Off means the UPS operates normally.

3.2 Components

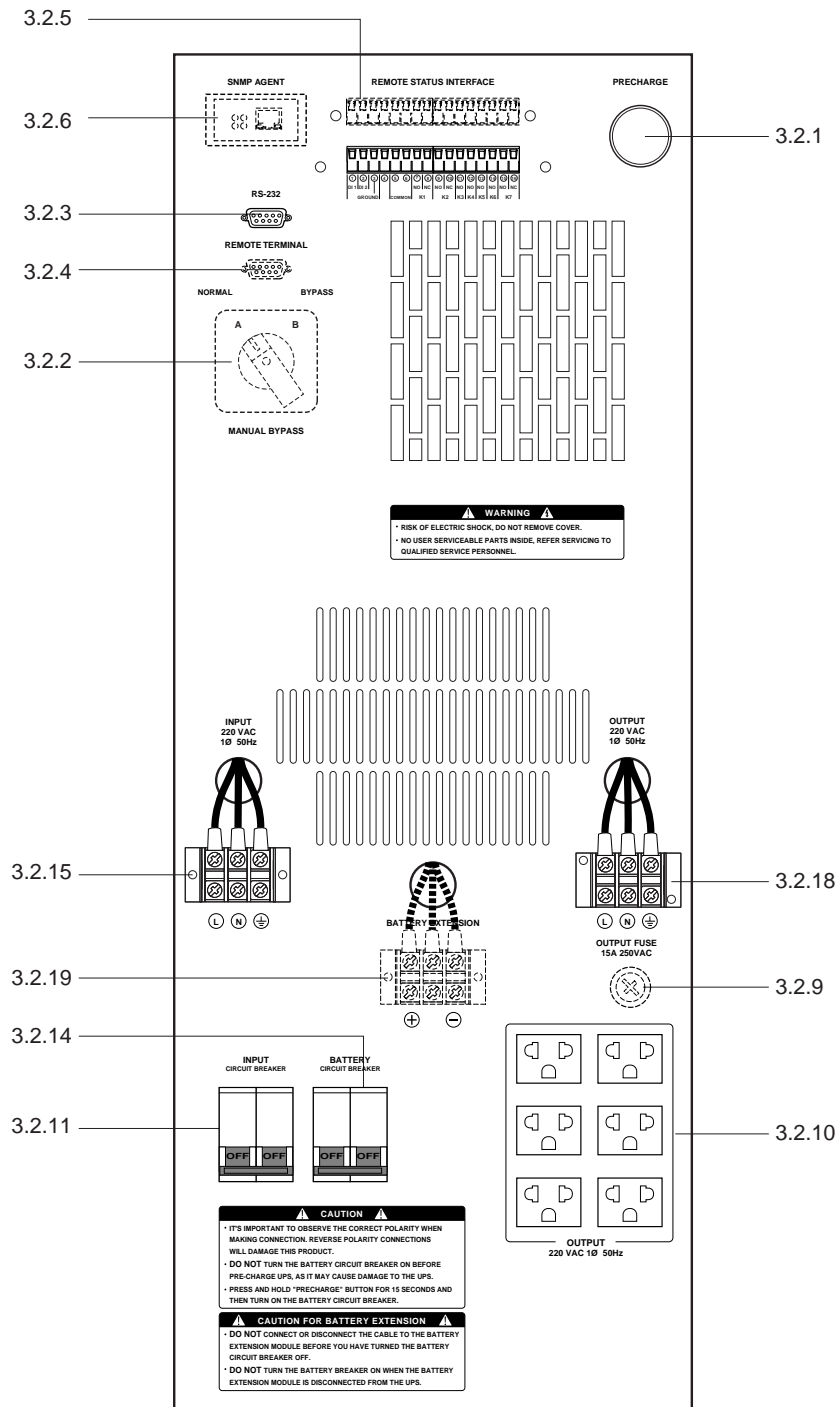

Rear panel of NB-2KS UPS

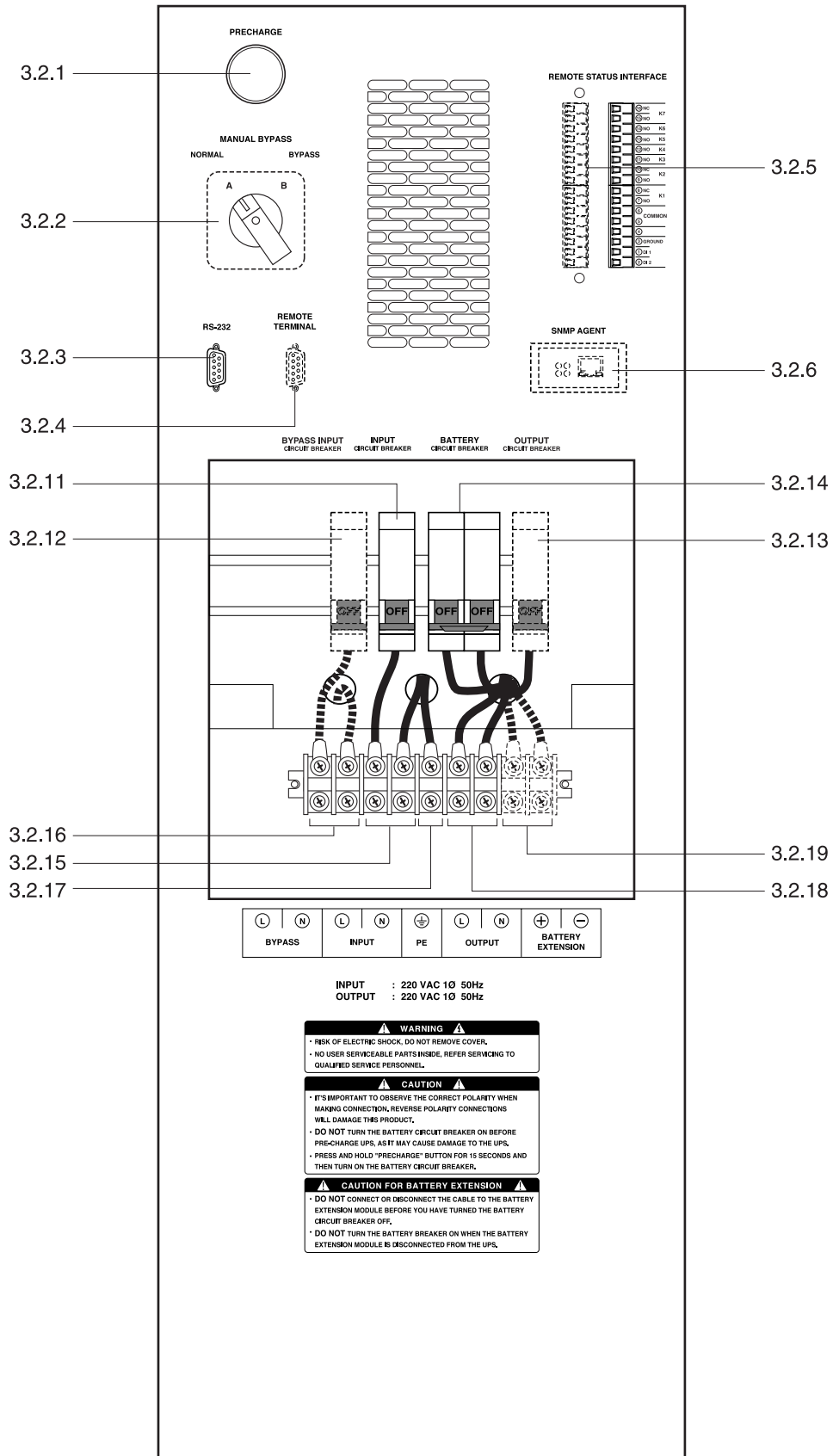

Rear panel of NBP-3KS, NBP-5KS and NBP-6KS UPS

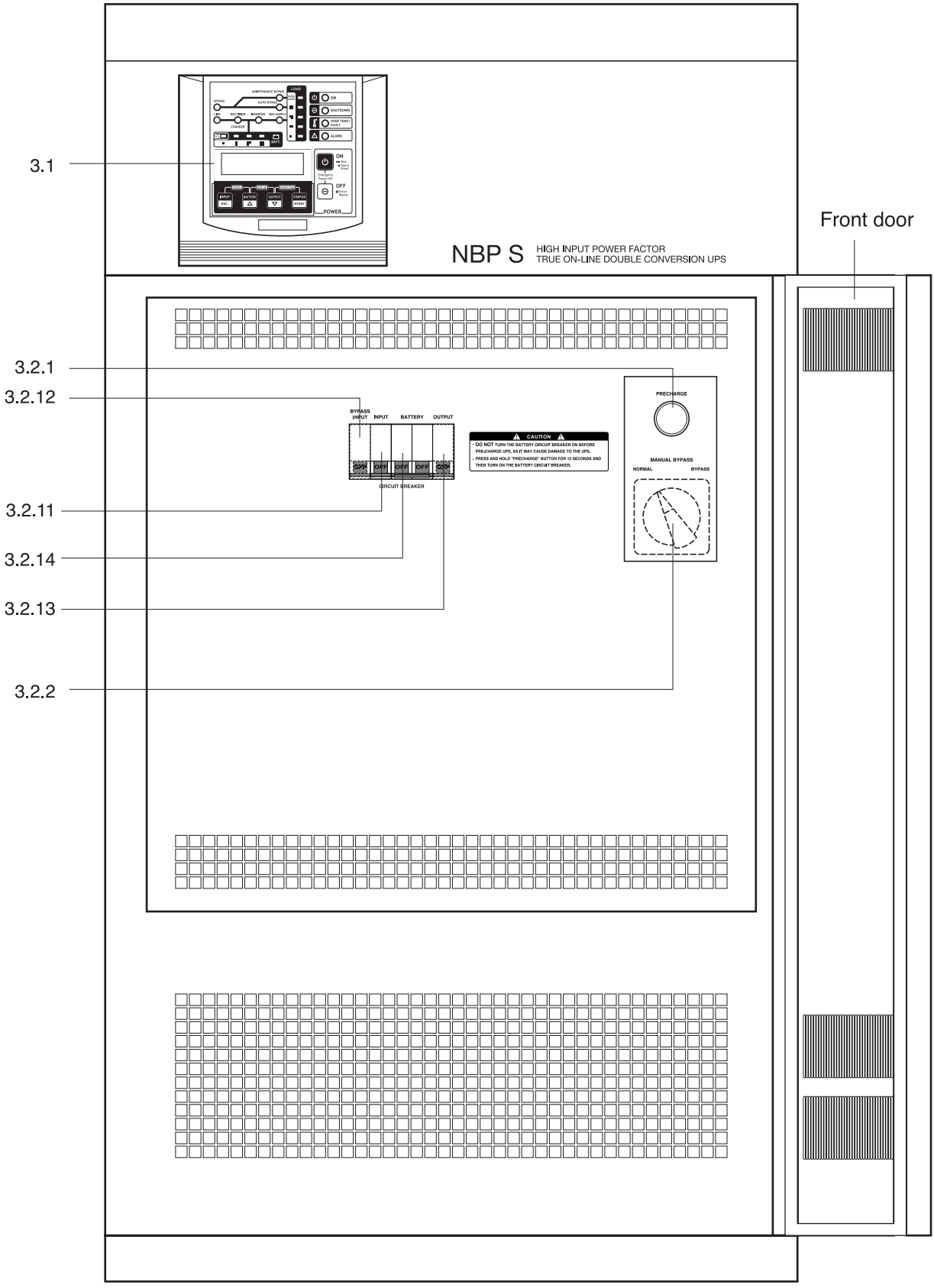

Front panel of NBP-8KS and NBP-10KS UPS

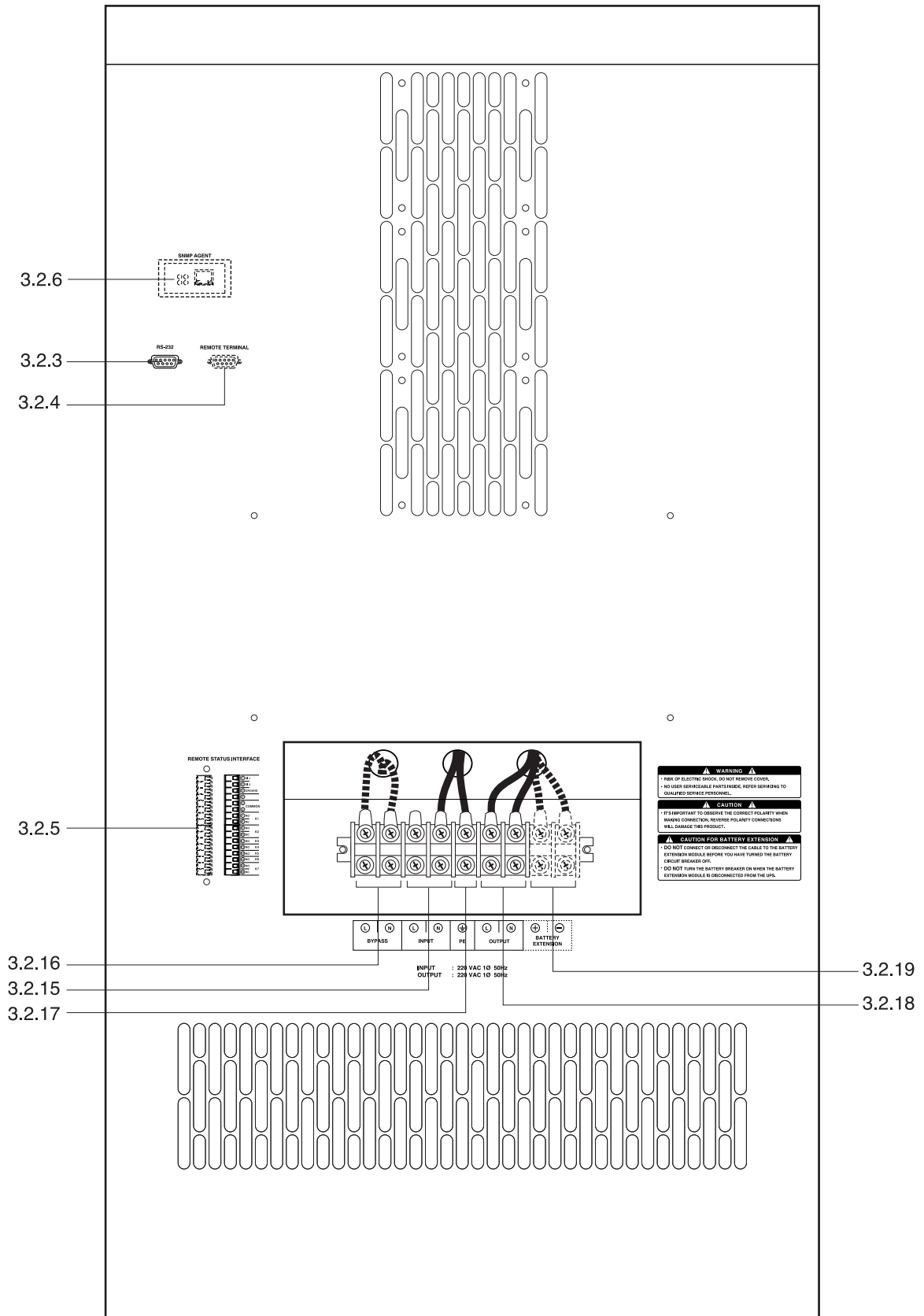

Rear panel of NBP-8KS and NBP-10KS UPS

- 3.2.1 **PRECHARGE**: A button to press and hold for 5 seconds before turn on BATTERY circuit breaker every time for safety. The capacitor will first charge in order to protect surge or spark when urn on BATTERY circuit breaker.
- 3.2.2 **MAINTENANCE MANUAL BYPASS SWITCH (option)**: The switch to switch power source from AC utility power to BYPASS power source for maintenance.
 - NORMAL/AUTO: Select this position to tranfer loads to consume the protected power from UPS.
 - BYPASS: Select this position to transfer loads to consume power from bypass power source when the UPS need to maintenance.
- 3.2.3 **RS232-PC**: The port for connecting RS-232 cable from UPS to computer to send and receive electricity data with Easy-Mon X (download Easy-Mon X at www.leonics.com).
- 3.2.4 **REMOTE TERMINAL (option)**: The port to send and receive remote signal to display the operation of the UPS via remote display or website.
- 3.2.5 **REMOTE STATUS INTERFACE (option)**: The terminal for sending remote contact signal; normally open (NO), normally close (NC) and common (COM) to display the operating status of the UPS. The descriptions of each signal pin are as follow.
 - 3.2.5.1 DI1: Reserved.
 - 3.2.5.2 DI1: Reserved.
 - 3.2.5.3 GROUND: ground of digital input signal.
 - 3.2.5.4 COMMON: COMMON pin of the contact signal.
 - 3.2.5.5 K1 (NO, NC): UPS Normal / Fault (NO and NC contacts of K1 relay).
 - 3.2.5.6 K2 (NO, NC): Loads are protected. (NO and NC contacts of K2 relay).
 - 3.2.5.7 K3 (NO): Run on battery signal (NO contact of K3 relay).
 - 3.2.5.8 K4 (NO): Bypass signal (NO contact of K4 relay).
 - 3.2.5.9 K5 (NO): Low battery signal (NO contact of K5 relay).
 - 3.2.5.10 K6 (NO): Overload signal (NO contact of K6 relay).
 - 3.2.5.11 K7 (NO, NC): Alarm signal (NO and NC contacts of K7 relay).
- 3.2.6 **SNMP AGENT (option)**: The socket for connecting computer network LAN cable to view electricity data and UPS status via SNMP/HTTP (Read more details in Net Agent manual).
- 3.2.7 **AC INPUT**: The cable for connecting to AC outlet or AC power source (specific models only).
- 3.2.8 **INPUT FUSE**: The component for protecting from overload or short circuit current at the UPS input.
- 3.2.9 **OUTPUT FUSE**: The component for protecting loads from overload or short circuit current at the UPS output (specific models only).
- 3.2.10 **UPS OUTPUT**: The socket to supply protect backup power to loads (specific models only).
- 3.2.11 **INPUT circuit breaker**: The circuit breaker for protecting from overload or short circuit current at the main AC power source.
- 3.2.12 **BYPASS INPUT circuit breaker (option)**: The circuit breaker for protecting from overload or short circuit current at bypass power source.
- 3.2.13 **OUTPUT circuit breaker (option)**: The circuit breaker for protecting loads from overload or short circuit current at the UPS output.
- 3.2.14 **BATTERY circuit breaker**: The circuit breaker for protecting from overload or short circuit current at the battery system.
- 3.2.15 **INPUT terminal**: The terminal for connecting input power from main AC power source to the UPS.
- 3.2.16 **BYPASS INPUT terminal**: The terminal for connecting input power from bypass power source to the UPS.
- 3.2.17 **PE/EARTH terminal (⊕)**: The terminal for connecting to ground system.
- 3.2.18 **OUTPUT terminal**: The terminal for connecting to loads.
- 3.2.19 **BATTERY EXTENSION terminal(option)**: The terminal for connecting to external battery bank to extend backup time.

INSTALLATION

4.1 Preparation

- 4.1.1 Before you install the UPS, give it a through visual examination to ensure it has not been subjected to shipping damage. If it is not in perfect condition, please contact your local distributor or service center or e-mail to support@leonics.com.
- 4.1.2 Installation of the UPS must be done by professional technicians only. Before installing or using this unit, read all instructions, caution markings on the UPS and all connected load, and all sections of this user guide.
- 4.1.3 Check the mains input voltage and all connected load power rating to suit for UPS power rating.
- 4.1.4 Transportation
- 4.1.4.1 UPS has been fitted with casters to allow ease of transportation. UPS must be moved vertically.
- 4.1.4.2 Transport the UPS with its packaging until it arrive the installation location to avoid shipping damages.
- 4.1.4 Location
- 4.1.5.1 For 2000 VA model or lower: Install the UPS at least 20 cm at the side and back to enable easy access for installation, operation and maintenance.
- 4.1.5.2 For 3000 VA model or higher: Install the UPS at least 80 cm free space around the UPS to enable easy access for installation, operation and maintenance.
- 4.1.5.3 Install at the floor that is capable of supporting the weight of the UPS.
- 4.1.5.4 Battery Extension Modules must be installed near by the UPS.
- 4.1.6 Working with Battery Extension Modules
- Batteries are connected in series which have hazardous voltage upto 306-400 Vdc. Any battery connection must be done by qualified technician only.

Warning: DO NOT work with batteries when UPS is operating.

4.1.7 Cable size

The cable sizes in the following table are calculated based on TIS.11-2531 PVC insulated copper wire, 70 degree Celsius conductor temperature, 750 Volt 40 degree Celsius ambient temperature and maximum 3 wires per conduit.

| Power rating | 1000 VA or lower | 2000 VA | 3000 VA | 5000 VA | 6000 VA | 8000 VA | 10000 VA |
|-----------------------------|------------------|---------|---------|---------|---------|---------|----------|
| Main input cable (sq.mm.) | Power cord | 2.5 | 2.5 | 6 | 6 | 10 | 16 |
| Bypass input cable (sq.mm.) | - | 2.5 | 2.5 | 6 | 6 | 10 | 16 |
| Output cable (sq.mm.) | - | 1.5 | 2.5 | 4 | 6 | 6-10 | 16 |
| PE/Earth cable (⊕) (sq.mm.) | - | 1.5 | 2.5 | 4 | 4 | 4 | 6 |

- Note:**
- Maximum cable length must not exceed 10 metres. If in need of cable longer than 10 metres, properly increase cable size to accommodate excessive length.
 - For your safety, all cables should be wire in the suitable size conduits.
 - The above data is for standard product only.
 - For the battery extension module installation, please contact us.

4.2 Installation

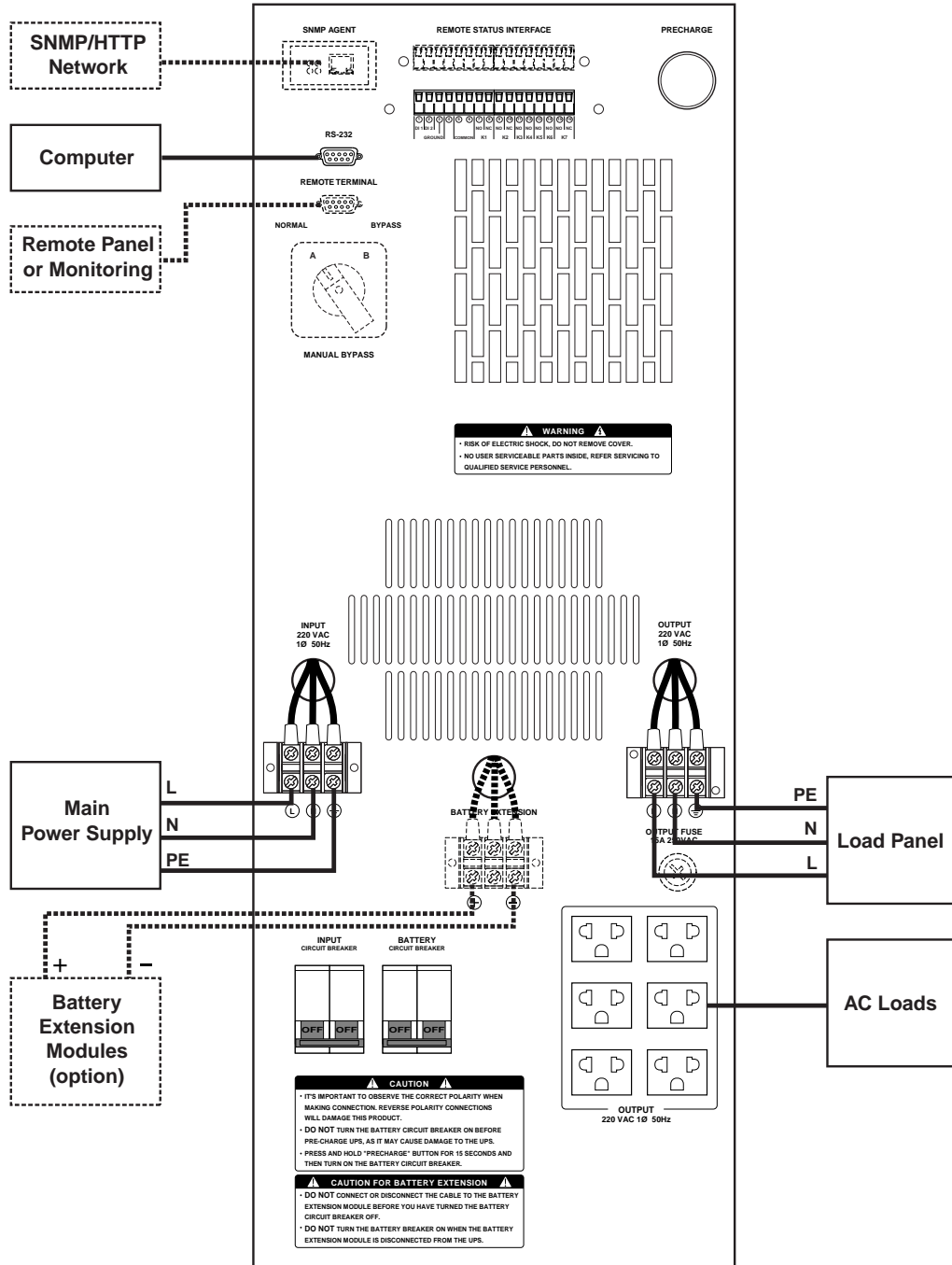

Installation diagram of NB-2KS UPS

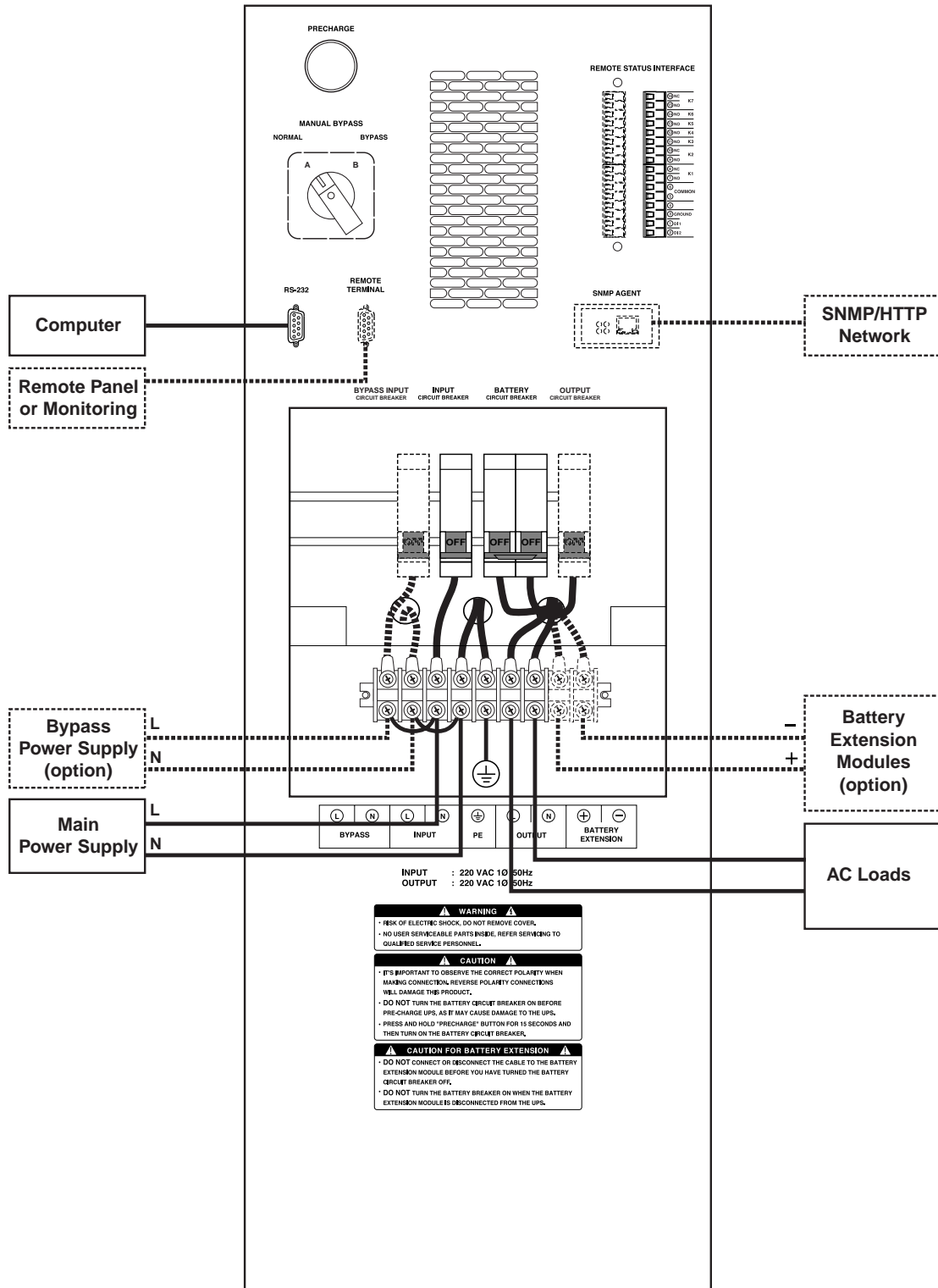

Installation diagram of NBP- 3KS,NBP -5KS and NBP-6KS UPS

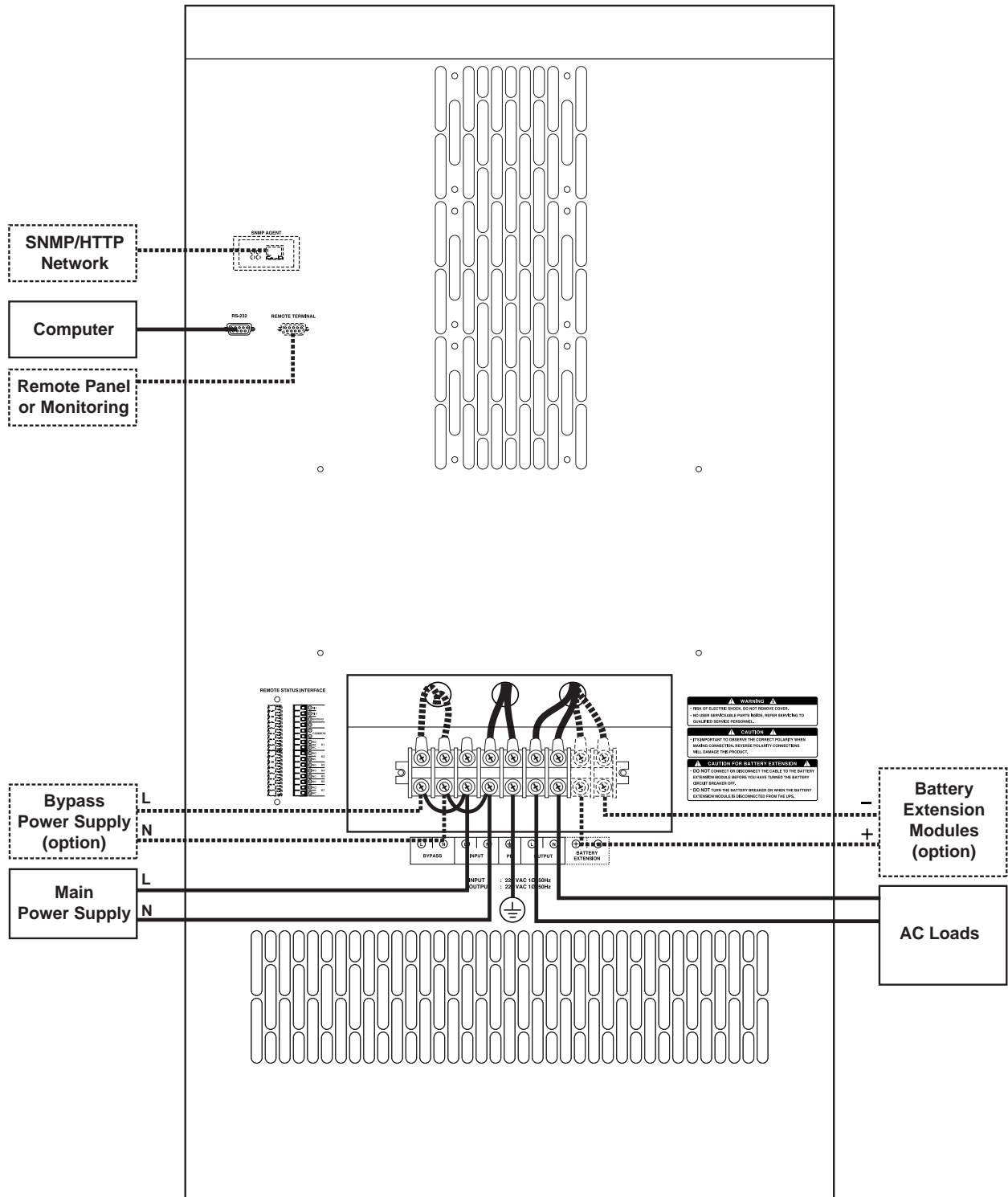

Installation diagram of NBP- 8KS and NBP-10KS UPS

- Note:**
- For the single power source, it has to jump the cables between BYPASS INPUT terminal and MAIN INPUT terminal of the UPS as shown in the installation diagram figures.
 - If there are two power sources, it has to disconnect the jumping cables between BYPASS INPUT terminal and MAIN INPUT terminal.

- 4.2.1 Turn off all loads.
- 4.2.2 For 2000VA model or higher, Turn off all AC power source which supplies power to the UPS .
- 4.2.3 Turn off INPUT, BYPASS INPUT (if available), OUTPUT (if available) and BATTERY circuit breakers.
- 4.2.4 Connect RS-232 signal cable (if available) from the computer serial port to RS-232-PC port of the UPS.
- 4.2.5 Connect Remote terminal signal cable (if available) from remote panel or modem to REMOTE TERMINAL port of the UPS.
- 4.2.6 Connect interface signal cables (if available) at REMOTE STATUS INTERFACE terminal to send and receive remote contact signal (NO, NC, COM) for control or alarm such as PLC or buzzer.

Sample

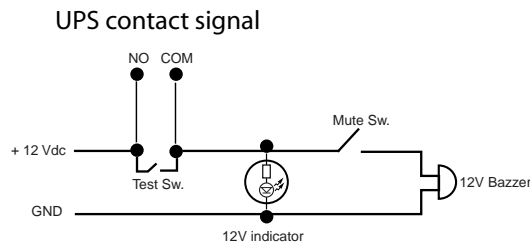

Note: Contact rating 5A 250Vac / 5A 30Vdc

- 4.2.7 Connect earth cable at PE / EARTH (⊕) terminal.
- 4.2.8 Connect input cable from AC power source to the UPS.
 - For 1500 VA model or higher, connect the cable from AC power source at INPUT terminal of the UPS. Connect NEUTRAL at N terminal of the UPS and connect LINE at L terminal of the UPS.
 - If there is single power source, jump BYPASS input terminal to INPUT terminal. If there is other power source which is not primary power source, connect to BYPASS input terminal.
- 4.2.9 Connect loads to UPS.
 - 4.2.9.1 For 1000 VA model or lower, connect loads to UPS OUTPUT outlets at the rear side of the UPS.
 - 4.2.9.2 For 1500 VA model or higher, connect the cable from OUTPUT terminal of the UPS to loads. Connect NEUTRAL at N terminal of the UPS and connect LINE at L terminal of the UPS.
- 4.2.10 In case of battery extension, remove fuse from the fuse holder or turn off circuit breaker at the battery extension unit before connecting to the UPS. Then connect the positive (+) of the battery extension unit to the positive (+) terminal of the UPS. And connect the negative (-) of the battery extension unit to the negative (-) terminal of the UPS.
- 4.2.11 Verify all connections.

OPERATION

5.1 Start-up the UPS

5.1.1 For 1000 VA model or lower

5.1.1.1 Turn off all loads.

5.1.1.2 Press and hold PRECHARGE button for 5 seconds or until the LCD lit, then release. Turn on BATTERY circuit breaker. BATTERY LEVEL indicator shows battery level.

Caution: DO NOT turn on BATTERY circuit breaker before precharge the UPS because the UPS may be damaged.

Note: In case of battery extension, turn on BATTERY circuit breaker or FUSE circuit breaker (if available) of the battery extension unit before pressing PRECHARGE button and turning on BATTERY circuit breaker at the UPS.

5.1.1.3 Plug input cable or input power cord to AC receptacle. INPUT, BYPASS and RECTIFIER/CHARGER indicators are lit.

5.1.1.4 Press and hold ON button for 2 seconds or until alarm beep sound to turn on the UPS. The ON indicator blinks and UPS start up self-test automatically. After self test, if the UPS operates normally, the display will show the operating status

5.1.1.5 Turn on connected loads.

5.1.2 For 1500 VA model or higher

5.1.2.1 Turn off all loads.

5.1.2.2 Press and hold PRECHARGE button for 5 seconds or until the LCD lit, then release. Turn on BATTERY circuit breaker. BATTERY LEVEL indicator shows battery level.

Caution: DO NOT turn on BATTERY circuit breaker before precharge the UPS because the UPS may be damaged.

Note: In case of battery extension, turn on BATTERY circuit breaker or FUSE circuit breaker (if available) of the battery extension unit before pressing PRECHARGE button and turning on BATTERY circuit breaker at the UPS.

5.1.2.3 Turn on INPUT circuit breaker and BYPASS circuit breaker (if available). INPUT, BYPASS and RECTIFIER/CHARGER indicators are lit.

5.1.2.4 Press and hold ON button for 2 seconds or until alarm beep sound to turn on the UPS. The ON indicator blinks and UPS start up self-test automatically. After self test, if the UPS operates normally, the display will show the operating status

5.1.2.5 Turn on OUTPUT circuit breaker (if available).

5.1.2.6 Turn on connected loads.

5.2 Turning on and off the UPS for the next time

After finished the start-up procedure, press and hold OFF button until alarm beep sound once then release to turn off the UPS. To turn on the UPS at the next time, Only press and hold ON button until alarm beep sound once then release.

5.3 When blackout or power fails

When blackout or power fails, the UPS continuously supplies power to loads for 15-90 minutes (depending on load quantity and UPS power rating). UPS draw backup power from battery (INV. SUPPLY and ALARM indicators blink and alarm sound). When the backup power in the battery is low, LOW BATT. indicator (the 2nd from left) will blink and alarm sound rapidly to warn that the UPS will shutdown in a few minutes (Low

Battery Shutdown status). If the power returns to normal before the UPS goes to Low Battery Shutdown mode, UPS will switch back to consume power from AC utility power and charge battery automatically.

5.4 When UPS is overloaded

When UPS is overloaded (OVERLOAD indicator lit, ALARM indicator blinks and alarm sound), the AUTOMATIC TRANSFER SWITCH will transfer load to consume power from bypass power source directly (AUTO BYPASS indicator blinks and alarm sound) for preventing the UPS damage. User should reduce some loads until load quantity is about 75% and control the quantity not exceed 100% in order to make the loads consume power from the UPS all the time.

5.5 No load shutdown mode

When the UPS is supplying backup power and there is no connected loads, UPS will shutdown automatically after supplies backup power for 10 minutes in order to reserve the battery power. This feature is set disabled in the standard product. (This feature is available in the UPS with Battery save / No Load Shutdown mode)

5.6 Economy mode

Economy mode is an energy saving mode. In this operating mode, UPS transfer loads to consume power from bypass power source when the bypass power source is normal and run the INVERTER operation to be the backup source when the bypass power source fails.

5.7 Sleep mode

Sleep mode is an energy saving mode. In this operating mode, UPS transfer loads to consume power from bypass power source and stop the INVERTER operation when UPS found no connected load or load consume power from the UPS is lower than no load condition setting. During Sleep mode, If there are loads greater than set value, the INVERTER section will restart automatically and exit from sleep mode.

When UPS found no load and bypass power source fails, UPS will start INVERTER section and stand by to be the backup power source when there is load.

5.8 UPS self-test

UPS tests the operation of RECTIFIER, CHARGER and INVERTER section. There are 4 types of self-test.

5.8.1 Start-up self-test

When press ON button to start-up the UPS, it tests the operation automatically.

5.8.2 Manual self-test

When the UPS is operating, double click the ON button to start manual self-test.

5.8.3 Schedule self-test (option)

User can set UPS self-test schedule via Easy-Mon X (Read more details in Easy-Mon X user's guide in the CD-ROM or at www.leonics.com).

5.8.4 Auto self-test (option)

User can set UPS self-test automatically every 2 weeks or every day. This feature is disabled in the standard product.

Every test, if the battery is fully charged, the UPS will also check if the battery is still in good condition or need to be replaced.

5.9 Self-test cancellation

Before the UPS starts INVERTER section test, user can double click the ON button to cancel the self-test.

5.10 Mute alarm sound

Press the ON button once to mute the alarm sound. User can notice the alarm from ALARM indicator.

5.11 Force bypass

Press and hold OFF button for 8 seconds or until AUTO BYPASS indicator is lit and then release to force bypass. The UPS will alarm to inform the user that loads are consuming power directly from bypass power source. To transfer loads to consume protected power from the UPS again, press and hold ON button for 2 seconds or until alarm beep sound then release.

5.12 Manual maintenance bypass

- 5.12.1 Press and hold OFF button for 8 seconds or until AUTO BYPASS indicator is lit and then release to force bypass. The UPS will alarm to inform the user that loads are consuming power directly from bypass power source.
- 5.12.2 Turn the MAINTENANCE MANUAL BYPASS switch to position BYPASS (B). MAINTENANCE BYPASS indicator is lit.
- 5.12.3 Press and hold OFF button until alarm beep sound to turn off the UPS.
- 5.12.4 Turn off INPUT circuit breaker.
- 5.12.5 Turn off BATTERY circuit breaker.
- 5.12.6 Contact service center.

Once the UPS is recovered, start-up the UPS following the start-up procedure. Then turn the MAINTENANCE MANUAL BYPASS switch to position AUTO (A).













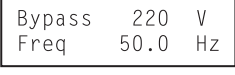

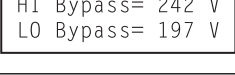
5.13 Emergency power off (EPO)

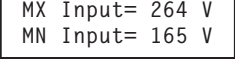
The Emergency Power Off is controlled by microprocessor. Press ON and OFF button simultaneously for 3 seconds. UPS will stop all operations include INVERTER, RECTIFIER and CHARGER operation, but the battery still supply power to microprocessor. To maintain battery power, turn off all circuit breakers by turn off the BATTERY circuit breaker at last.







LCD DISPLAY DESCRIPTION

Press , ,  or  to display data on the LCD display.







6.1 button

| | | | |
|-------|--|---|---|
| 6.1.1 | Press  buttons once |  | Displays MAIN INPUT voltage. |
| 6.1.2 | Press  buttons once again |  | Displays BYPASS INPUT voltage and input frequency. |
| 6.1.3 | Press  buttons once again |  | Displays the set value of high and low BYPASS INPUT voltage. |
| 6.1.4 | Press  buttons once again |  | Displays the set value of maximum and minimum acceptable input voltage of the UPS. |
| 6.1.5 | Press  buttons once again |  | Displays the setting of ECONOMY and SLEEP energy saving mode. |
| 6.1.6 | Press  buttons once again |  | Displays the set value of battery mode (no load shutdown) and break transfer (allow break transfer in not synchronize condition). |
| 6.1.7 | Press  buttons once again |  | Displays the set value of STATIC BYPASS SWITCH (enable/disable) and BYPASS condition check before transfer loads from MAIN input to BYPASS input. |
| 6.1.8 | Press  buttons once again |  | Return to the first screen. |









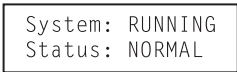

6.2  **button**

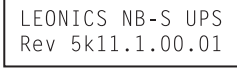

| | | | |
|-------|---|--------------------------------------|--|
| 6.2.1 | Press  buttons once | BATTERY CAP 100 % Bat-Tempr --- C | Displays battery capacity in percentage and battery temperature(option). |
| 6.2.2 | Press  buttons once again | Battery V 404 V I battery 0.2 A | Displays battery voltage and battery current. |
| 6.2.3 | Press  buttons once again | ESTIMATE RUNTIME 0 Hr 30 Min | Displays estimated backup time. |
| 6.2.4 | Press  buttons once again | Float CHG= 402 V Boost CHG= 420 V | Displays the set value of float charge voltage and boost charge voltage. |
| 6.2.5 | Press  buttons once again | CHGRMODE: FOAT Battery 7.0 AH | Displays charging mode and battery capacity. |
| 6.2.6 | Press  buttons once again | BATTERY CAP 100 % Bat Temp --- °C | Return to the first screen. |

6.3  **button**



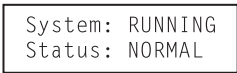

| | | | |
|-------|--|------------------------------------|--|
| 6.3.1 | Press  buttons once | UPS O/P 221 V Freq 50.0 Hz | Displays UPS output voltage and output frequency. |
| 6.3.2 | Press  buttons once again | %Load 47 % O/P I 8.8 A | Displays load level in percentage and output current. |
| 6.3.3 | Press  buttons once again | Power 1.90 kW Load Pf 1.00 | Displays load power and load power factor(option). |
| 6.3.4 | Press  buttons once again | Inverter 221 V INV-Tempr 37 °C | Displays inverter voltage and inverter temperature. |
| 6.3.5 | Press  buttons once again | OP set= 221.5 V Fq set= 50.0 Hz | Displays the set value of output inverter voltage and output inverter frequency. |
| 6.3.6 | Press  buttons once again | Syn MX= 53.0 Hz Syn MN= 47.0 Hz | Displays the set value of maximum and minimum acceptable frequency of Bypass power source. |
| 6.3.7 | Press  buttons once again | UPS O/P 220 V Freq 50.0 Hz | Return to the first screen. |

6.4  **button**

| | | | |
|-------|---|--|---|
| 6.4.1 | Press  buttons once |  | Displays the present operation and the status of the UPS. |
| 6.4.2 | Press  buttons once again |  | Displays the status of INVERTER, CHARGER, TRANSFER SWITCH and RECTIFIER section. |
| 6.4.3 | Press  buttons once again |  | Displays the condition of INVERTER, CHARGER, TRANSFER SWITCH and RECTIFIER section. ("OK" means "normal") |
| 6.4.4 | Press  buttons once again |  | Displays firmware version. |
| 6.4.5 | Press  buttons once again |  | Displays present date and time. (option) |
| 6.4.6 | Press  buttons once again |  | Return to the first screen. |

Note: If there is fault event recorded in the event log, while user presses  button, the message will show on the screen. Press  button again to view more events. At the end of the fault event lists, the screen will return the first screen.

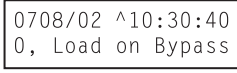
6.5  and  **button (Option)**







| | | | |
|-------|---|---|---|
| 6.5.1 | Press and hold  and  buttons simultaneously for 3 seconds |  | Displays date, time and fault event. Press  or  button to view other events. |
|-------|---|---|---|

Note: - " ^ " is shown at the latest event.
- The meaning of the first alphabet of the second row are as following

- 1 : Event happened
- 0 : Return to normal
- A : Automatic run
- R : Receive command via RS-232 or remote terminal
- P : Self test passed
- F : Self test failed
- M : Manual control





| | | | |
|-------|---|--|---|
| 6.5.2 | Press  button once | <div style="border: 1px solid black; padding: 5px; width: fit-content; margin: auto;"> EVENT LOGGING RECORD# 000 </div> | Display the order of the event. 0 is the latest event. Maximum events are 256 records |
|-------|---|--|---|

SETTING









To enter system control setting, press  buttons simultaneously for 3 seconds. Press  button to confirm the new set value or press  or  button to toggle menu. To exit system control setting menu, press  and  buttons simultaneously once or leave it for 30 seconds, the UPS will return to main screen automatically.

Note: Any parameter changes must be done by Leonics certified technicians only.





7.1 Enter password

















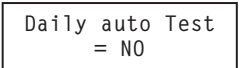

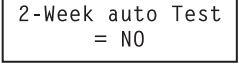

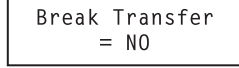
User must enter the password before change the system control set value. Press  and  buttons simultaneously for 3 seconds. To confirm the new set value, press  and  buttons simultaneously once.

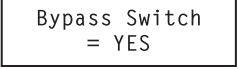
Example: Password is 2468.





| | | | |
|-------|---|---|---|
| 7.1.1 | Press  and  buttons simultaneously for 3 seconds. | <div style="border: 1px solid black; padding: 5px; width: fit-content; margin: auto;"> ENTER PASSWORD 0000 </div> | Enter password input screen. |
| 7.1.2 | Press  button | <div style="border: 1px solid black; padding: 5px; width: fit-content; margin: auto;"> ENTER PASSWORD 2000 </div> | Enters the 1 st digit of password. |
| 7.1.3 | Press  button | <div style="border: 1px solid black; padding: 5px; width: fit-content; margin: auto;"> ENTER PASSWORD 2400 </div> | Enters the 2 nd digit of password. |
| 7.1.4 | Press  button | <div style="border: 1px solid black; padding: 5px; width: fit-content; margin: auto;"> ENTER PASSWORD 2460 </div> | Enters the 3 rd digit of password |
| 7.1.5 | Press  button | <div style="border: 1px solid black; padding: 5px; width: fit-content; margin: auto;"> ENTER PASSWORD 2468 </div> | Enters the last digit of password. |
| 7.1.6 | Press  and  button simultaneously once | <div style="border: 1px solid black; padding: 5px; width: fit-content; margin: auto;"> SYSTEM CONTROL SETTING </div> | Confirms password. If the input password is correct, the next screen will be shown. |

7.2 System control setting















After user inputs the correct password, system control set values can be changed. To change the value, press  button. Then press  or  button to toggle the value. Press  button to confirm the new setting or press  button to cancel.

| | | | |
|--------|--|---|--|
| 7.2.1 | Press  and  buttons simultaneously once. |  | Enters system control setting. |
| 7.2.2 | Press  button once. |  | Confirms to enter system control setting. Then, sets equalize charge system. |
| 7.2.3 | Press  button once again. |  | Sets daily automatic self-test (option). |
| 7.2.4 | Press  button once again. |  | Sets 2-week automatic self-test (option). |
| 7.2.5 | Press  button once again. |  | Sets break transfer (allow break during transfer in not synchronize condition). |
| 7.2.6 | Press  button once again. |  | Sets static bypass switch (enable/disable). |
| 7.2.7 | Press  button once again. |  | Sets bypass condition check before transfer loads from MAIN input to BYPASS input. |
| 7.2.8 | Press  button once again. |  | Sets ECONOMY energy saving mode. |
| 7.2.9 | Press  button once again. |  | Sets SLEEP energy saving mode. |
| 7.2.10 | Press  button once again. |  | Sets battery saving mode (no load shutdown). |













7.3 Time and date setting







After user inputs the correct password, time and date can be changed. To change the value, press  button. Then press  or  button to toggle the value. Press  button to confirm the new setting or press  button to cancel.

7.3.1 Time setting

| | | | |
|---------|--|---|---|
| 7.3.1.1 | Press  and  buttons simultaneously once. |  | Enters system control setting. |
| 7.3.1.2 | Press  button once. |  | Select time and date setting menu. |
| 7.3.1.3 | Press  button once . |  | Confirms to enter time and date setting menu. Then enters time setting. |
| 7.3.1.4 | Press  button once again. |  | Confirms to enter time setting. Sets hour. |
| 7.3.1.5 | Press  button once again. |  | Confirms new time (hour). Sets minute. |
| 7.3.1.6 | Press  button once again. |  | Confirms new time (minute). Sets second. |
| 7.3.1.7 | Press  button once again. |  | Confirms new time (second).. |





7.3.2 Date setting















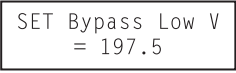

| | | | |
|---------|--|---|---|
| 7.3.2.1 | Press  and  buttons simultaneously once. |  | Enters system control setting. |
| 7.3.2.2 | Press  button once. |  | Select time and date setting menu. |
| 7.3.2.3 | Press  button once . |  | Confirms to enter time and date setting menu. |
| 7.3.2.4 | Press  button once. |  | Select date setting menu. |
| 7.3.2.5 | Press  button once. |  | Confirms to enter date setting. Sets year. |
| 7.3.2.6 | Press  button once again. |  | Confirms date (year). Sets month. |

| | | | |
|---------|---|---|-----------------------------------|
| 7.3.2.7 | Press  buttons once again. |  | Confirms date (month). Sets date. |
| 7.3.2.8 | Press  button once again. |  | Confirms date (date). Sets day. |
| 7.3.2.9 | Press  button once again. |  | Confirms day. |

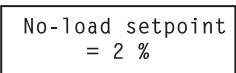
7.4 Parameter setting

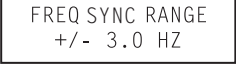
After user inputs the correct password, parameter values can be changed. To change the value, press

 button. Then press  or  button to toggle the value. Press  button to confirm the new setting or press  button to cancel.

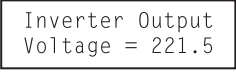
| | | | |
|-------|--|---|---|
| 7.4.1 | Press  and  buttons simultaneously once. |  | Enters system control setting. |
| 7.4.2 | Press  button twice. |  | Enters system data setting. |
| 7.4.3 | Press  button once. |  | Confirms to enter system data setting and displays set value of low bypass input voltage. |
| 7.4.4 | Press  button once. |  | Displays special converter output frequency set value. The value can be set to one decimal place. |
| 7.4.5 | Press  button once again. |  | Displays set value of no load condition in percentage. |
| 7.4.6 | Press  button once again. |  | Displays set value of synchronize output frequency range. |
| 7.4.7 | Press  button once again. |  | Displays set value of output frequency. |
| 7.4.8 | Press  button once again. |  | Displays set value of inverter output voltage. |

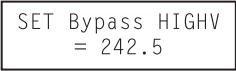
| | | | |
|-------|---|---|--|
| 7.4.9 | Press  buttons once again. |  | Displays set value of high bypass input voltage. |
|-------|---|---|--|

MAINTENANCE

8.1 UPS

LEONICS UPS does not need any special maintenance. Just only keep it away from dust and humidity. Anyway, if any of following items occurred, please contact us or our nearest service center.

- Part of the cable is cut, broken or damaged.
- The inside is wet with and kind of liquids.
- The metal cabinet is broken, dropped, fallen, crashed or hit.
- User notices abnormal conditions under normal use.

8.2 Battery

Even though the backup batteries are maintenance free, user still need to check them every year to make sure that they are at good condition. Always use the batteries and recharge them immediately when the power is low. If the UPS is not used or keep for long time, recharge the UPS for 8 hours every 3 months. Follow the following the procedure below to recharge the battery.

8.2.1 For 1000 VA model or lower

8.2.1.1 Press and hold PRECHARGE button for 5 seconds or until the LCD lit, then release. Turn on BATTERY circuit breaker. BATTERY LEVEL LEDs shows battery level.

8.2.1.2 Plug input cable or input power cord to AC receptacle. Charge the UPS for 8 hours.

8.2.2 For 1500 VA model or higher

8.2.2.1 Press and hold PRECHARGE button for 5 seconds or until the LCD lit, then release. Turn on BATTERY circuit breaker. BATTERY LEVEL LEDs shows battery level.



8.2.2.2 Turn on INPUT circuit breaker and BYPASS circuit breaker (if any). Charge the UPS for 8 hours.

Caution: Do not do anything with the battery while the UPS is operating.

TROUBLESHOOTING

If the UPS does not operate properly and you cannot solve the problems using this troubleshooting information in this user's guide, please contact your LEONICS local distributor, LEONICS Service Center, send e-mail to support@leonics.com or visit www.leonics.com.

| Symptoms | Possible causes | Solutions |
|---|--|--|
| Press and hold PRECHARGE button for 5-8 seconds. No any indicator is lit. | Reverse battery polarity connection | Reconnect battery system and verify the poles. |
| Once the UPS started, MAINTENANCE BYPASS indicator is lit, ALARM indicator blinks and alarm sound. | MAINTENANCE BYPASS switch is at position BYPASS (B). | Turn MAINTENANCE BYPASS switch is at position AUTO (A) . |
| 2 BATTERY LEVEL indicators are lit, ALARM indicator blinks and alarm sound. | Low battery power. | <ol style="list-style-type: none"> 1. Press ON button to mute the alarm sound. 2. Turn off loads. 3. Wait until the battery is fully charged then turn on loads again. |
| The UPS shuts down. SHUTDOWN indicator is lit, 1-2 BATTERY LEVEL indicators are lit, ALARM indicator blinks and alarm sound. | The UPS supplied power from battery until the battery power is very low and then the UPS shuts down automatically. | <ol style="list-style-type: none"> 1. Press ON button to mute alarm sound. 2. Turn off loads. 3. Restart the UPS 4. Wait until the battery is fully charged then turn on loads again. |
| 1 BATTERY LEVEL indicator is lit, ALARM indicator blinks and alarm sound. | Battery capacity is too low and need to be replaced. | <ol style="list-style-type: none"> 1. Press ON button to mute the alarm sound. 2. Turn off loads. 3. Turn off the UPS. 4. Turn off OUTPUT (if any), INPUT, BYPASS INPUT (if available) and BATTERY circuit breakers. 5. For 1000 VA model or lower, unplug AC power cord from utility power. 6. Replace new battery that is same type and rating. 7. Start-up the UPS again . |
| OVERLOAD indicator lit, ALARM indicator blinks and alarm sound. | UPS is overloaded. | Disconnect some loads until the load quantity is less than the UPS power rating. |
| OVERLOAD indicator is lit, ALARM indicator blinks and alarm sound. | The UPS was overloaded for long time until shutdown automatically. | <ol style="list-style-type: none"> 1. Press ON button to mute alarm sound. 2. Disconnect some loads until the load quantity is less than the UPS capacity. 3. Press ON button to start and reset the UPS. |

| Symptoms | Possible causes | Solutions |
|--|---|---|
| SHUTDOWN indicator is lit, ALARM indicator blinks, OVER TEMP./FAULT is lit or blinks and alarm sound. | The UPS is over temperature. | <ol style="list-style-type: none"> 1. Press ON button to mute the alarm sound. 2. Turn off loads. 3. Press OFF button to shutdown the UPS. 4. Wait until the temperature is cool then restart the UPS again. |
| | The UPS has fault. | <ol style="list-style-type: none"> 1. Press ON button to mute the alarm sound. 2. Press  button to view fault events. Then contact service center. |
| Once the UPS started, UPS alarms a short beep sound periodically. | The UPS has fault. | <ol style="list-style-type: none"> 1. Press ON button to mute the alarm sound. 2. Press  button to view fault events. Then contact service center. |
| The UPS operates normally but sound a short beep periodically or the UPS supplies backup power for a short time and returns to normal operating. | A power sag occurred in too short a period for the user to sense. But the UPS can detect that abnormal condition. | No need to do anything. |
| Blackout occurred and UPS supplies backup power. But when the utility power returns to normal, the UPS still supplies backup power. | The input voltage is out of range which is too high or too low voltage. | <ol style="list-style-type: none"> 1. Press ON button to mute alarm sound. 2. Turn off loads and wait until the input power is in the acceptable range (the UPS operates normally) then turn on loads again. |
| Once start-up the UPS, any circuit breaker has tripped. | UPS is overloaded or short circuited or the circuit breaker is improper rating. | <ol style="list-style-type: none"> 1. Turn off the UPS. 2. Recalculate and verify the system. 3. Check circuit breaker rating. 4. If the circuit breaker trips again when restart the UPS, contact service center. |
| The UPS operates normally but does not supplies power to loads. | OUTPUT circuit breaker (if available) is turned off. | Turn on OUTPUT circuit breaker (if available). |
| | OUTPUT FUSE is blown. | <ol style="list-style-type: none"> 1. Turn off the UPS 2. Check if the fuse is blown, replace new one with same type and rating. |
| Power source is normal but the UPS supplies backup power. | INPUT circuit breaker is turned off. | Turn on INPUT circuit breaker. |
| | INPUT FUSE is blown (if available). | <ol style="list-style-type: none"> 1. turn off the UPS 2. Check if the fuse is blown, replace new one with same type and rating. |

SOFTWARE INSTALLATION

- 10.1 Turn off computer and UPS before connecting RS-232 cable from the computer to the UPS.
- 10.2 Turn on the UPS and then turn on the computer. Then insert the Easy-Mon X Software CD into CD-ROM Drive or download at www.leonics.com.
- 10.3 The Macromedia Flash presentation program will shown automatically. Press ESC button on the keyboard to exit the Macromedia Flash presentation. Then the Easy-Mon X window will be shown on screen.

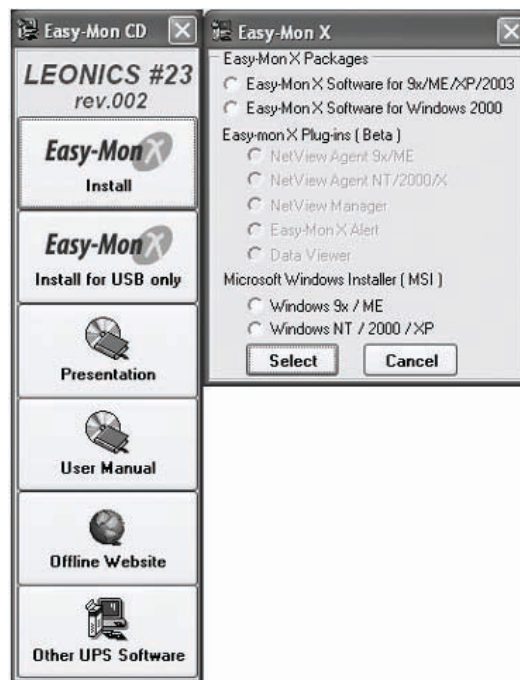

- 10.4 Click the "Easy-Mon X Install" button and then install Easy-Mon X Package which relates to your computer operating system.
- 10.5 Follow the instruction as shown on screen.
- 10.6 After finished the Easy-Mon X installation, restart the computer.
- 10.7 Start the "Easy-Mon X Setup" program and then click the "Auto Detect UPS" to search for the UPS model and communication port automatically.
- 10.8 Once you know the communication port, start the "Easy-Mon X Spy" program to monitor the UPS data.

Note :- The values of input (Vin) and output (Vout) voltages read from the Easy-Mon X Software from many UPSs in the same network may be different, even though connected to the same power source. Possible causes of these happenings are the voltage over each branch circuit is not equal, or $\pm 1\%$ accuracy of input and output voltage measuring circuit, or the UPSs are connected to different power phases of the same source.

- You can find more information about Easy-Mon X in the Easy-Mon X Software CD.