

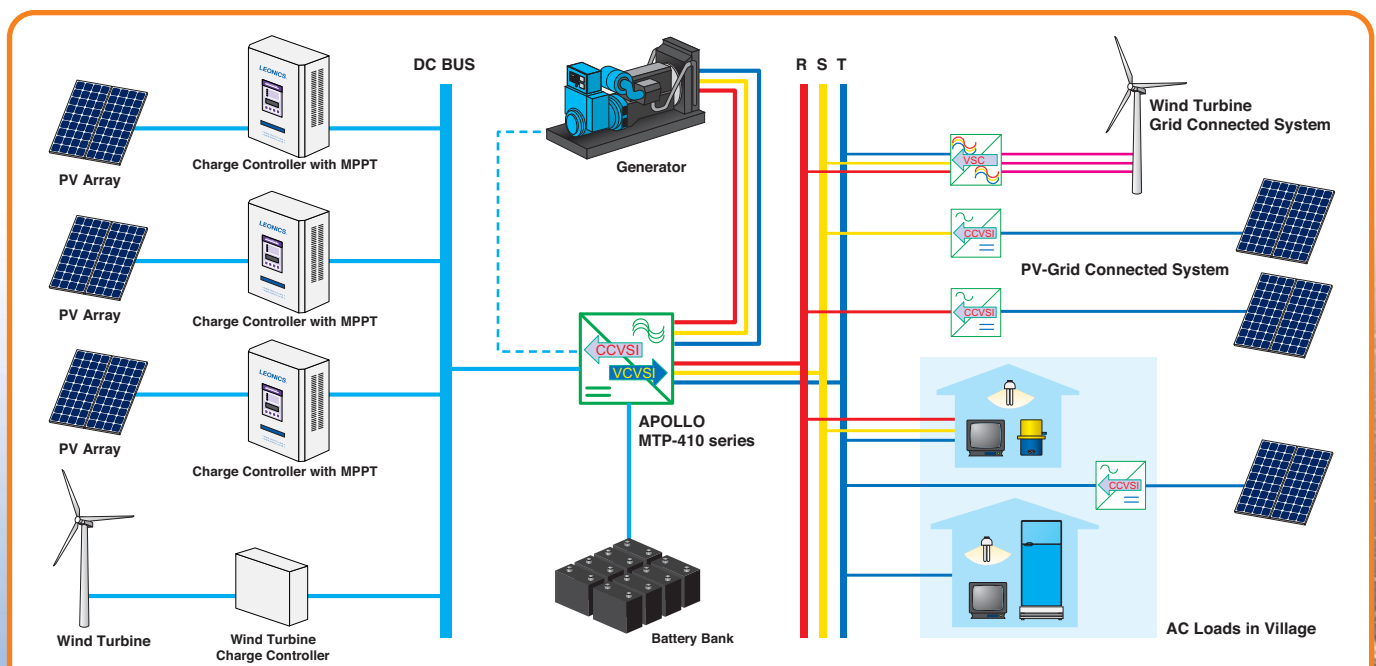

APOLLO MTP-410

THREE PHASE BIDIRECTIONAL DUAL MODE HYBRID INVERTER FOR MINI-GRID SYSTEM

- Capable to use with multiple renewable energy sources in both DC coupling and AC coupling such as solar panel, wind turbine generator and micro hydro generator
- Separate DC Bus for multiple source charging
- Monitor energy available from the renewable energy (DC) sources and minimize the charging current from the diesel generator.
- Automatic / Manual generator control
- DC external charge control
- Automatic battery equalization (option) to prevent battery capacity loss and prolong battery life
- Battery temperature compensation (option)
- Preset time schedule by System Command Unit (SCU) for automatic controlling the auxiliary power sources such as generators in mini-grid system (option)
- ISO 9001 and ISO 14001 certified factory
- Three phase bidirectional inverter with built-in output transformer
- Low harmonic distortion (less than 4%)
- High efficiency more than 94%
- High reliability design for remote area



The APOLLO MTP-410 Series is a three phase bidirectional dual mode hybrid inverter capable of functioning as a main supply source as well as providing automatic control and management of a generator and a battery bank. The inverter features very high efficiency in both charger and inverter modes with maximum efficiency of 94%. It's suitable for supplement diesel generator in off-grid areas.

SPECIFICATIONS

MODEL		MTP-412E	MTP-413E	MTP-414F	MTP-415F	MTP-416F	MTP-417G	MTP-418G	MTP-419G	MTP-4110G
RATED POWER		15 kW	25 kW	30 kW	45 kW	60 kW	75 kW	90 kW	100 kW	120 kW
BATTERY	Nominal Voltage	120 Vdc			240 Vdc			360 Vdc		
	Maximum charging current	84 A	130 A	84 A	125 A	168 A	140 A	168 A	186 A	220 A
EXTERNAL DC CHARGER	Nominal voltage	120 Vdc			240 Vdc			360 Vdc		
	Maximum current	100 A	200 A	100 A	200 A	200 A	200 A	250 A	250 A	300 A
	DC charge control	Relay dry contact 10 A (for over external charge protection)								
AC INPUT FROM GENERATOR	Recommended generator power rating	> 30 kW	> 50 kW	> 60 kW	> 90 kW	> 120 kW	> 150 kW	> 180 kW	> 200 kW	> 240 kW
	Voltage	380 / 400 / 415 Vac (L-L), 220 / 230 / 240 Vac (L-N) ± 10%								
	Phase	Three phase								
	Frequency	50 / 60 Hz ± 3 Hz								
	Automatic start/stop	Relay dry contact 10 A (ACC on and start pluse)								
AC OUTPUT	Voltage	380 / 400 / 415 Vac (L-L), 220 / 230 / 240 Vac (L-N)								
	Voltage regulation	± 3% (steady load), < 7% at 100% step load within 0.1 sec.								
	Phase	Three phase								
	Frequency	50 / 60 Hz ± 0.1% (auto sensing)								
	Wave form	Pure sine wave								
	Total harmonic distortion	total < 4%								
	Maximum surge current	200%								
ISOLATION	Galvanic isolation	yes								
EFFICIENCY	Inverter peak efficiency	94%								
PROTECTION		Over current, Over load, Short circuit, Over temperature, Over voltage, Under voltage								
INDICATOR	LED	Generator Running, Generator Failure, Stand by/Run, Inverter, Charging, Load on Inverter, Overload, Low Battery, High temperature, Fault								
	LCD display	Inverter voltage, Inverter current, Inverter frequency, Inverter power, Generator voltage, Generator current, Generator frequency, Generator power, Load voltage, Load current, Load power, Battery voltage, Battery current, Battery state of charge(%), Internal charging current, External DC charging current, Battery temperature (option), Equalization Date, Today Energy (Inverter, Generator, Battery), Accumulated energy (Inverter, Generator, Battery), System status, Time, Date, Heat sink temperature, Data Log								
AUDIABLE ALARM		Low battery, Inverter fault, High temperature								
COOLING		Automatic cooling fan								
ENVIRONMENT	Temperature	0 - 45°C								
	Relative humidity	0 - 95 % (Non - condensing)								
DESIGN STANDARD		AS/NZ 3100:2002								
DIMENSION	Control Unit	60 x 188 x 105			90 x 188 x 105			80 x 205 x 105		
	Transformer Unit	-			-			120 x 205 x 105		
WEIGHT (approximate in kg.)	Control Unit	218	380	380	470	745	850	590	590	600
	Transformer Unit	-	-	-	-	-	-	990	1,045	1,150

Continuous product development is our commitment. In that manner, the above specifications may be changed without prior notice.

Authorized Distributor:

LEO ELECTRONICS CO.,LTD.

119/50-51 MOO 8 BANGNA-TRAD RD., BANGNA, BANGNA, BANGKOK 10260 THAILAND.
Tel. 66-2746-9500, 66-2746-8708 Fax. 66-2746-8712
http://www.leonics.com • e-mail : RNE@leonics.com

Authorized Dealer: